

Modernization Kit No. 4750409 High Volume Label Removal

Barry-Wehmiller now offers the latest advancement in label removal to retrofit Bottle Washer machines. Model 14 and System 40 & 100, Bottle Washers can be modified to incorporate this new design, allowing a simplified, more effective method of label removal.

The HVLR pump pulls solution down through the center section of the soak tank. The center section of the tank is separated from the outer section by solid sheet deflectors. Label-free solution moves over the heating coils to the suction intake side of the pump.

The pump discharge returns the fluid up both outer sections of the soak tank, where the solution cascades with a directed flow through submerged bottle carriers. The force of flow pushes the bottles back to the deflector bars, providing an area for the labels to be swept from the internal carrier. The free labels then follow the directed flow in the upper portion of the tank, through the Moving Screen Separator equipped with a continually moving stainless steel mesh conveyor. Our unique design of this moving screen system requires no slack take-up rollers or adjustment points on the mesh conveyor, as the weight of the screen and the solution flow maintains a natural catenary sag to the mesh screen conveyor. The strained solution flows back to the center section of the tank, to the pump, repeating the same cycle. The mesh then conveys the labels out of the solution bath and into the drop-off area discharge chute. Label and debris removed from the compartment may be deposited in a collection container.

Label removal is made simple through this “High Flow” label removal system and problems associated with other methods of label removal are eliminated. I.E. The need of agitators and internal bottom tank

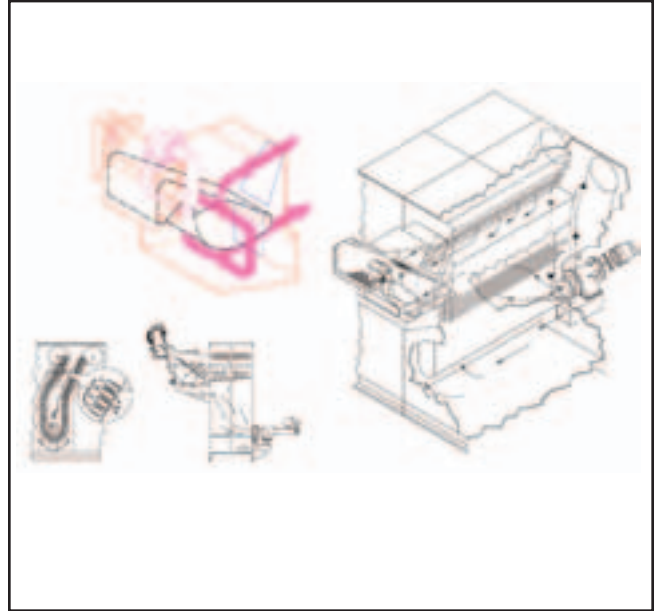

pipings, external solution filters, and programing are no longer required for label removal. As the continuous high flow allows whole labels to be gently removed from the compartment in the shortest possible time and subjects the paper to a minimum of turbulence.

Barry-Wehmiller offers this highly-efficient, field-tested modernization to retrofit your existing equipment. Reductions in down-time and savings in caustic/water usage are realized after installing the High Volume Label Removal System.

Please contact us to evaluate your application. Please contact your Barry-Wehmiller Customer Service Department for details.